

Standard Full Nut

Thread Type: Metric - Coarse

Thread Direction: Right Hand

Material: Nylon

Class Grade: Low Tensile Class 4.6

Finish: White

Corrosion Protection Level: Excellent

Standard: DIN 934

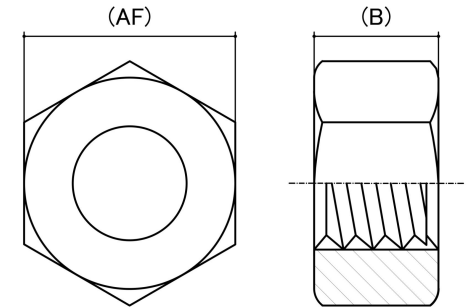

*CAD drawings shown for graphic representation only.**

Size	Thread Pitch (mm)	Thread Type	Overall Nut Height (B) (mm)		Across Flats (AF) (mm)		Spanner Size (AF) (mm)	sku (qfind)
			Min	Max	Min	Max		
M2	0.40	Coarse	1.35	1.75	3.82	4.00	4	41NY2
M2.5	0.45	Coarse	1.75	2.00	4.82	5.00	5	41NY25
M3	0.50	Coarse	2.15	2.40	5.32	5.50	5.5	41NY3
M4	0.70	Coarse	2.90	3.30	6.78	7.00	7	41NY4
M5	0.80	Coarse	3.70	4.00	7.78	8.00	8	41NY5
M6	1.00	Coarse	4.70	5.00	9.78	10.00	10	41NY6
M8	1.25	Coarse	6.14	6.40	12.73	13.00	13	41NY8
M10	1.50	Coarse	7.42	8.00	16.73	17.00	17	41NY10
M12	1.75	Coarse	9.64	10.00	18.67	19.00	19	41NY12
M16	2.00	Coarse	12.30	13.00	23.67	24.00	24	41NY16
M20	2.50	Coarse	15.00	16.00	29.16	30.00	30	41NY20

Disclaimer:

Dimensional data and technical information was obtained from publicly available sources and not acquired through standard agencies. It has been completed and compiled for reference purposes only; where discrepancies are found they are subject to change without notice. Bolt & Nut Australia makes no warranties or representations regarding the accuracy and validity of the compiled information and data. Contact the relevant standard authorities for accurate and detailed information.

* CAD drawings may not reflect diameter, thread length or overall length.

© Bolt & Nut Australia Pty Ltd. All rights reserved.

Version: 18 Mar 2024